

# MAGIX<sup>®</sup>

## AlphaPRO

# DATASHEET



## Incredible speeds plus rock-solid reliability

Magix's AlphaPRO SSD drive dramatically improves the responsiveness of your existing system with incredible boot, loading and transfer times compared to mechanical hard drives. Powered by the latest-gen controller for reading and writing speeds up to 550MB/s and 520MB/s, this SSD is much faster than a traditional hard drive for higher performance, ultra-responsive multi-tasking and an overall faster system. Also more reliable and durable than a hard drive, AlphaPRO is built with Flash memory. There are no moving parts, making it less likely to fail than a mechanical hard drive. It is also cooler and quieter, and its shock and vibration resistance makes it ideal for notebooks and other mobile computing devices. AlphaPRO is available in multiple capacities from 128GB to 1TB to give you all the space you need for applications, videos, photos and other important documents. You can also replace your hard drive or a smaller SSD with a drive big enough to hold all your files.

This SSD is designed for desktop and notebook computer workloads and not intended for Server environments.

## OVERVIEW:

- > Fast start-up
- > Fast application loading
- > Fast file data transfer speed
- > More reliable and durable than a regular hard drive
- > Multiple capacities with space for applications or a hard drive replacement
- > Long life Cycle



## DATASHEET

### SPECIFICATIONS:

- > **Form factor:** 2.5"
- > **Interface:** SATA Rev. 3.0 (6Gb/s) – with backwards compatibility to SATA Rev. 2.0 (3Gb/s)
- > **Capacities\*:** 128GB, 256GB, 512GB, 1TB
- > **Read/Write performance\*\*:**
  - 128GB — up to 500MB/s Read and 490MB/s Write
  - 256GB — up to 520MB/s Read and 500MB/s Write
  - 512GB — up to 550MB/s Read and 520MB/s Write
  - 1TB — up to 550MB/s Read and 520MB/s Write
- > **Flash Type:** 3D TLC
- > **ECC Scheme:** Proprietary NANDXtend™ ECC
- > **Storage temperature:** -40°C~85°C
- > **Operating temperature:** 0°C~70°C
- > **Dimensions:** 100.0mm x 69.85mm x 7.0mm (2.5")
- > **Weight:** 41g (2.5")
- > **Life expectancy:** 1.5 million hours MTBF
- > **Warranty/support\*\*\*:** Limited 5 -year warranty with free technical support
- > **Total Bytes Written (TBW):**
  - 128GB — 60 TBW
  - 256GB — 120 TBW
  - 512GB — 240 TB W
  - 1TB — 500 TBW



### MAGIX PART NUMBERS:

- > **128GB:** ALPHAPRO128GB
- > **256GB:** ALPHAPRO256GB
- > **512GB:** ALPHAPRO512GB
- > **1TB:** ALPHAPRO1TB

\*1TB = 1,000,000,000,000/1 000 000 000 000/1.000.000.000.000 bytes.  
1GB = 1,000,000,000/1 000 000 000/1.000.000.000 bytes. Some of the listed capacity on a Flash storage device is used for formatting and other functions and thus is not available for data storage. As such, the actual available capacity for data storage is less than what is listed on the products.

\*\*Performance measured using CrystalDiskMark 6.0.2 x64, write cache enabled, 1MB/sec = 1,048,576 bytes/sec ratio, msi X299 Chipset, Intel Core i7-7800K@3.5GHz, 32GB DDR4, Windows 10 x64 OS. Speed may vary due to host hardware, software, and usage.

\*\*\* Warranty conditions on [www.magixtechnology.com/wa](http://www.magixtechnology.com/wa)

# DATASHEET

## FUNCTION BLOCK DIAGRAM:

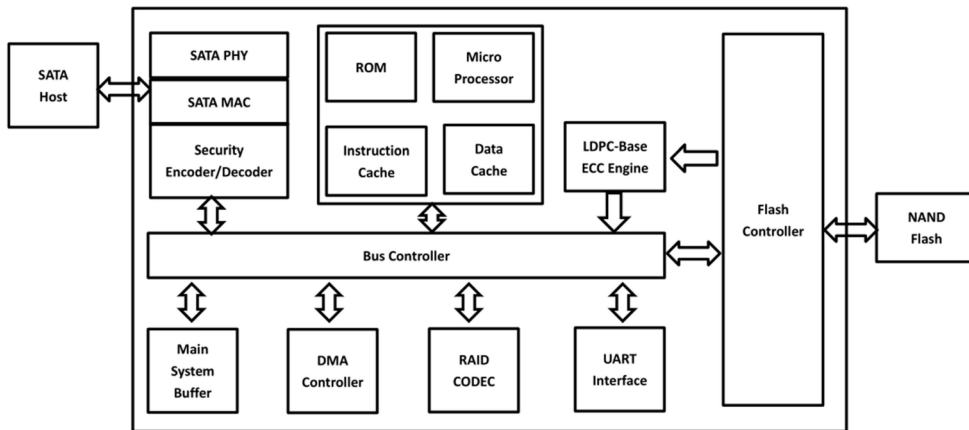

## MECHANICAL SPECIFICATION:

